

# majestic

# majestic

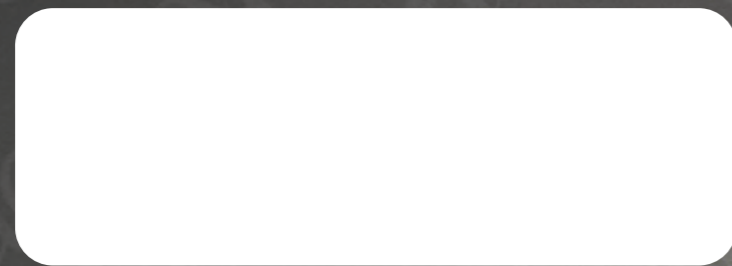

2011 Printed  
[www.majestic-percussion.com](http://www.majestic-percussion.com)

Specifications are subject to change without notice

## 2011 CATALOGUE



## Contents

<b>Introduction of Majestic</b>	<b>Page</b>	<b>2</b>
<b>Timpani – Grand Classic Series</b>	<b>Page</b>	<b>3 ~ 6</b>
<b>Timpani – Symphonic Grand Series</b>	<b>Page</b>	<b>7 ~ 10</b>
<b>Timpani – Prophonic Series</b>	<b>Page</b>	<b>11 ~ 14</b>
<b>Timpani – Symphonic Series</b>	<b>Page</b>	<b>15 ~ 18</b>
<b>Timpani – Harmonic Series</b>	<b>Page</b>	<b>19 ~ 20</b>
<b>Timpani – Concert Series</b>	<b>Page</b>	<b>21 ~ 22</b>
<b>Timpani Specifications</b>	<b>Page</b>	<b>23 ~ 24</b>
<b>Accessories</b>	<b>Page</b>	<b>25 ~ 26</b>
<b>Concert Bass Drums</b>	<b>Page</b>	<b>27 ~ 28</b>
<b>Concert Toms</b>	<b>Page</b>	<b>29 ~ 30</b>
<b>Concert Snare Drums</b>	<b>Page</b>	<b>31 ~ 32</b>
<b>Concert Drums Specifications</b>	<b>Page</b>	<b>33 ~ 34</b>
<b>Marimbas</b>	<b>Page</b>	<b>35 ~ 38</b>
<b>Xylophones</b>	<b>Page</b>	<b>39 ~ 40</b>
<b>Vibraphones</b>	<b>Page</b>	<b>41 ~ 42</b>
<b>Bells</b>	<b>Page</b>	<b>43 ~ 44</b>
<b>Chimes</b>	<b>Page</b>	<b>45 ~ 46</b>
<b>Quantum Field Mallets</b>	<b>Page</b>	<b>47 ~ 51</b>
<b>Mallets Specifications and Scale Map</b>	<b>Page</b>	<b>52 ~ 53</b>
<b>Percussion Kits</b>	<b>Page</b>	<b>54</b>

## INTRODUCTION

### Performance Instruments preferred by Percussionists throughout the world



Majestic Factory 1927

The family firm of Van der Glas B.V. was founded in 1921 by Willem Klazes Van der Glas in the old city centre of Heerenveen, the Netherlands. Initially the company sold organs, pianos and wind instruments, but the production of percussion instruments soon followed.

In 1960 Majestic was born. With the growing popularity of drum sets at that time, the Majestic brand name was introduced on professional kits which were widely used by rock bands throughout Europe. By the late 60's Majestic marching and concert percussion were being produced and quickly became the central focus of the company's activities.

The growth and expansion of the Majestic product line continued to include a complete line of timpani which were quickly recognized for their tremendous quality of sound and craftsmanship.

Throughout its long history Majestic has employed a standard of excellence that remains their governing philosophy. Product development, engineering and production all abide by this philosophy to ensure that every instrument conforms to stringent standards of craftsmanship and performance.

Today, Majestic percussion instruments can be seen and heard at fine performances all over the globe. Majestic marching drums are played by such prestigious ensembles as the Russian army bands, the world-champion marching band DVS, and the European indoor percussion champion Percussion Unlimited. Majestic timpani are the choice of many of the finest schools and professional bands and orchestras around the world. Most recently, Majestic mallet instruments have quickly become the preferred brand of many discriminating percussion performers and educators, and are being used by such notables as the Ju Percussion Group, Janus Percussion, and Jazz vibraphonist Jason Marsalis.

From orchestras in Canada to the top DCI drum corps in the U.S. to ensembles in Chile; from the Bolshoi theatre in Russia to the National Symphony Orchestra in China to bands in New Zealand; Majestic is preferred by percussionists throughout the world.

Over the course of years Majestic has grown and evolved to include the complete line-up of percussion instruments that it offers today. You can be sure that this evolution will continue and that the Majestic brand will remain on the cutting edge, providing state of the art instruments to meet musicians needs. Engineers and performers are already collaborating to bring you the next exciting steps in the evolution of concert and marching percussion and the Majestic commitment to unmatched quality remains.



Majestic Factory Today



## Grand Classic Series

### Old traditions revived

Over the last 20 years many large and small timpani-building companies have attempted to copy the models of well-know German timpani builders from the early twentieth century. Unfortunately they have not looked critically at the old construction techniques, some of which have serious drawbacks. Majestic, in co-operation with many famous timpanists, has succeeded in building a timpani that revives the old traditions while using state-of-the-art techniques to eliminate any of these drawbacks.

### Kettle

The kettle is seamlessly deep-drawn from a single copper sheet using a computer-controlled deep-drawing press. This process guarantees optimum, consistent quality. The thickness and strength of each point on the kettle wall are exactly what they should be. After this deep-drawing process, the final tone of the timpani can be further refined by means of hammering.

### Hammering

With the Grand-Classic, you can choose from the following three options (at no additional cost):

- \* Non-hammered: offers a full, warm, dark sound with few overtones.
- \* Standard-hammered: for greater clarity of timbre due to a broader range of overtones.
- \* Fine-hammered: offers a luminously clear timbre with a broad range of overtones.

(Fine-hammered will be supplied unless otherwise requested.)

The hammering process is fully automated. As a result, the timbre-change on the 20" timpani is exactly the same as the timbre-change on the 32" timpani, guaranteeing a well-attuned set of timpani.

Timpani that you order later will also match perfectly with the rest of your set.

### Maarten Smit

Majestic Timpani Artist,  
Principal Timpanist, Netherlands Radio  
Philharmonic Orchestra

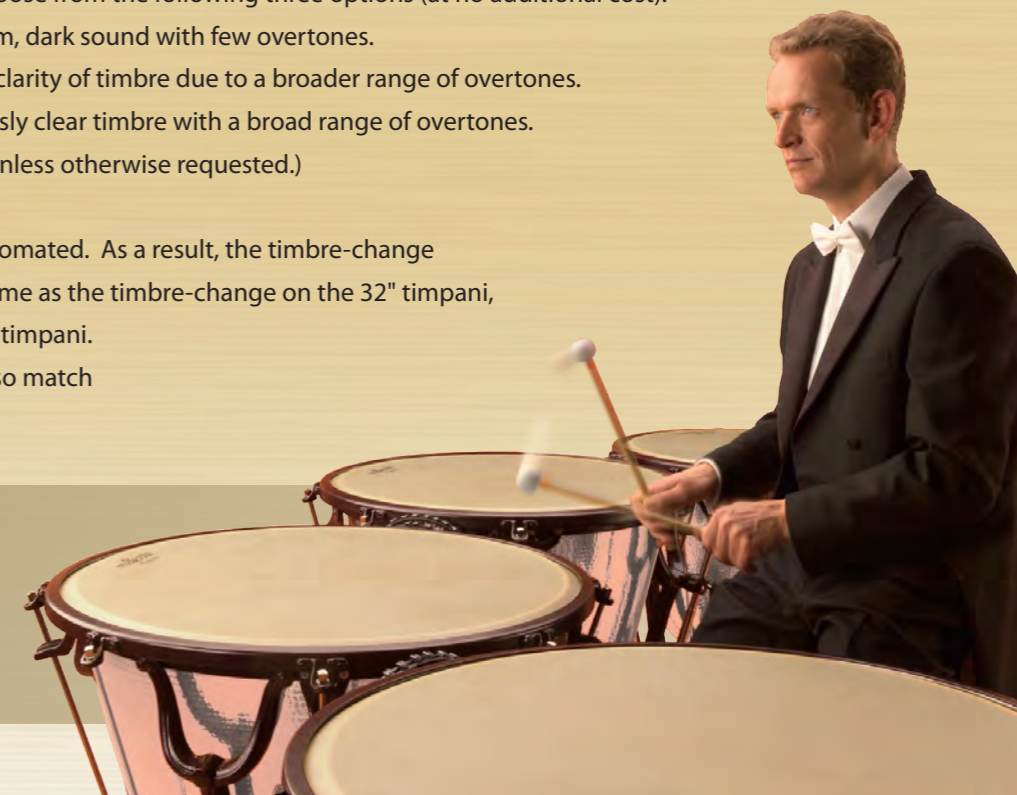

## Grand Classic Series

### Pedal systems

In addition to the various hammering methods, you can also choose between 3 different pedal systems within the Majestic Grand-Classic range. You will always be able to find a pedal system that is comfortable and that meets your needs. We offer the following pedal systems:



The Berlin system with stepless setting, also known as 'clutch interlocking' (GCBC model).

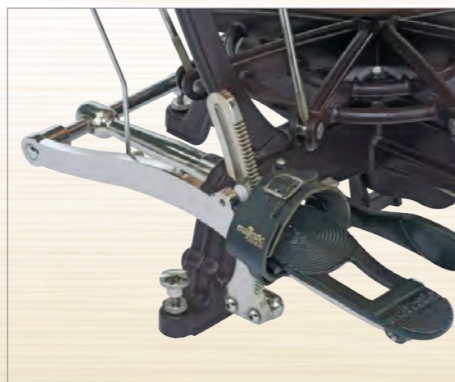

The Berlin system with ratchet setting, but much more refined than in the past (GCBR).



The Dresden system with stepless setting, also known as "clutch interlocking" (GCDC).



### Range and sizes

Majestic Grand-Classic timpani all have a range of more than 1 octave and come in the following sizes: 20", 23", 26", 29" and 32".

All of them may be ordered in either American or German set up. Tuning gauges will be placed accordingly.



### Transport wheels

The classic German timpani lacked transport wheels. Lifting and moving these instruments means considerable physical strain, which is no longer prudent today.

The Majestic Grand-Classic comes equipped with fully collapsible wheels (single-lever system) that fit inconspicuously underneath the timpani. While the instrument is being played, the metal frame remains in continuous contact with the stage, ensuring that the stage acts as a sort of soundboard.



### Finish

The gleaming metal parts have been traditionally nickel-plated (not chrome-plated). If desired, the tuning tension ring can also be nickel-plated at no extra charge.

Grand-Classics are typically used with super Kalfó timpani heads from Ireland, tucked in German style on steel flesh hoops. This option is available for an extra charge. Timpani come standard with Remo Renaissance heads.

Finally, the entire timpani is completely hand-assembled with great accuracy and precision by a traditional craftsman.

## Symphonic Grand Series

Majestic Symphonic-Grand timpani have been developed in the Netherlands' oldest percussion factory in collaboration with various prominent timpani players from all over the world. These timpani have been designed to include professional features and tone while incorporating a less complicated block style pedal system with both hand and foot fine tuners for easy and precise tuning.

Also available without fine tuners as Symphonic Grand Standard Line, for players who prefer the blocked pedal system but do not feel the need of fine tuners.

Easy transportability has also been taken into account: the stable cast frame is made of aluminium and has 2 double locking wheels in front and 2 wheels underneath the pedal for easy manoeuvring. Combining high performance features with state-of-the-art manufacturing, Majestic's Symphonic-Grand series makes professional level timpani available to a wider range of players.



### Kettle

The deep-drawn cambered kettle is manufactured from seamless copper. Form and depth are carefully calculated and construction takes place with the utmost precision. Because the rim on which the head rests forms part of the kettle, there is no resonance-distortion from any steel carrying rim on this instrument. The kettle's suspension in its frame guarantees total purity of sound. The copper kettle is available in both a hammered and non-hammered version depending on the desire for more or less overtones (brighter or darker sound).

### Pedals

A unique blocking system ensures that the pedal always remains exactly in the desired position. Applying slight pressure on the front unlocks the pedal. In addition to the main tuning pedal, this timpani has a unique fine-tuner pedal for easy fine-tuning even during actual playing.

### Range and sizes

Majestic Symphonic-Grand timpani all have a range of more than 1 octave and come in the following sizes: 20", 23", 26", 29" and 32".

All Majestic timpani can be ordered in either American or German set up. Tuning gauges will be placed accordingly.

### Heads

Symphonic-Grand Timpani are standardly equipped with Remo Renaissance heads. Original Irish calfskin heads are also available at an extra charge.



Highly accurate hand fine tuner



Unique foot fine tuner next to the tuning pedal for small tuning adjustments while playing the instrument

## Symphonic Grand Standard Series

Majestic Symphonic Grand timpani are also available without hand and foot fine tuners in the Symphonic Grand Standard Series. Timpani players who prefer the blocked pedal system, but do not need the additional fine tuners can now choose from this new series which has all the advantages and features of the Majestic Symphonic Grand timpani, but at a more attractive price. The copper kettle is available in both a hammered and non-hammered version.



### Tuning gauge

All Majestic timpani are fitted with an extremely accurate, easily adjustable and eye-pleasing tuning gauge.



Wheels below the pedal for easy transportation



Mallet / Key holder is mounted on every 26" timpani (at no extra charge)



## Prophonic Series

### Finally a transportable timpani with professional sound qualities

Until now timpani players had to choose between either collapsible timpani without a professional sound or professional sounding timpani without the possibility of easy transport. All of the folding timpani on the market had their complete tension mechanisms inside the kettles. The newly invented and patented Prophonic timpani have finally solved the challenge of a fully suspended and free sounding timpani kettle.

The Prophonic combines the superior sound quality of the Symphonic (Grand) series with the easy transportability of the Harmonic series. In fact, the legs around the kettle protect the copper from damage and denting. The deep cambered copper kettle is made out of a single copper sheet, from bottom to rim. The kettle is fully suspended because there is no tuning mechanism inside, no steel rims on top and no tension blocks mounted. The result is the best possible sound characteristics.

Majestic Prophonic timpani are easy to travel with – 4 pieces can be moved in larger vehicle and 2 pieces will fit inside the smallest car. They are also much easier to store because they need far less space than traditional timpani.

"I am very pleased that Majestic has found a way to make professional quality sound so incredibly portable. I can set up all four in about two minutes. They transport and store easily, sound great, and the pedal feel is really nice!"

#### Julian Fairbanks

Majestic Timpani Artist,  
Acclaimed Jazz Percussion Ensemble – "All Bluff & Portorage"



## Prophonic Series

### Kettle

The kettle is deep drawn from a single copper sheet in deep cambered form for optimal resonance and sustain. Available in the full range of sizes: 20", 23", 26", 29" and 32" with a choice between hammered or glossy polished finish.

Aluminium kettles are also available in the same deep cambered form as an economical alternative to copper and are finished in an attractive copper colour.

### Pedal

The pedal has a balance system with smooth action at any setting. Pedals on the back leg and both front legs are fully collapsible. A hand fine tuner is also available at an extra charge.

### Tuning gauge

All Majestic timpani are fitted with an extremely accurate, easily adjustable and eye-pleasing tuning gauge.

### Range and sizes

Majestic Prophonic timpani all have a range of almost 1 octave and come in the following sizes: 20", 23", 26", 29" and 32". All Majestic timpani can be ordered in either American or German set up. Tuning gauges will be placed accordingly.

### Heads

The Prophonic timpani come standard with Remo Renaissance heads.



Prophonic timpani unfolds in less than 15 seconds



One handle for foldable back leg with pedal



One handle for foldable front legs



Hand fine tuner available for an extra charge



Smooth operating balance pedal



Set of two in small car

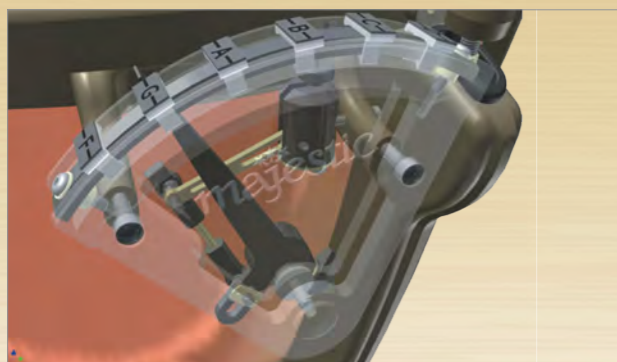

Tuning gauge





Set of 5 with deep cambered kettles

## Symphonic Series

### A timpani with extraordinary acoustic properties

Over 85 years of experience and expert advice from many top timpanists have gone into the making of the Majestic Symphonic timpani. The Majestic Symphonic is manufactured with state-of-the-art technology in an endeavour to achieve the ultimate in perfection. The result is a timpani with extraordinary acoustic properties, whether played fortissimo or pianissimo. Its warm, full-bodied timbre has tremendous carrying power while its pitch remains perfectly definable over the full range.

### Kettle

The deep cambered kettle is manufactured from seamless copper. Form and depth are carefully calculated and construction is carried out with the utmost precision. Because the rim on which the head rests forms part of the kettle, there is no resonance-distortion from any steel carrying rim on this instrument. The kettle's suspension in its frame guarantees total purity of sound. At an extra charge, the kettle is also available in a hammered copper version. In addition to the deep cambered version, a parabolic shape is also available.

### Tuning gauge

All Majestic timpani are fitted with an extremely accurate, easily adjustable and eye-pleasing tuning gauge.

### Pedal

A unique balance spring renders the pedal action pleasantly light, thanks in part to the special coating on the kettle rim. If required, the balance spring can be easily adjusted with an adjusting key on the bottom plate.

### Wheels

Majestic Symphonic timpani feature two swivelling castors with brakes and two fixed wheels beneath the pedal. This allows the timpani to be moved easily without having to be partially lifted.

### Ranges and sizes

Majestic Symphonic timpani all have a range of approximately 1 octave and come in the following sizes: 20", 23", 26", 29" and 32". All Majestic timpani can be ordered in either American or German set up. Tuning gauges will be placed accordingly.

### Heads and Frame

Symphonic timpani are standardly fitted with REMO Renaissance heads. The cast aluminium frame is both robust and pleasantly light.

### Symphonic Series

Symphonic timpani are also available with parabolic kettles



17



Remo®Renaissance heads as standard

18

Symphonic timpani can also be equipped with a parabolic / cambered Fiberglass kettle too!



Mallet Holder

All 26" timpani are fitted with a mallet holder (it also holds the tuning key)



Wheels

Wheels mounted under the pedal make the timpani easily transportable and manoeuvrable



Tension rod protection



Tuning gauge



Balance spring pedal



Balance adjusting key



Set of 4 with parabolic fiberglass kettles

## Harmonic Series

Majestic is the inventor of the easily transportable timpani with a balance spring pedal system. Many companies have tried to copy this but have been unsuccessful. The Harmonic is the economic version of the recently developed Prophonic series, without a free suspended kettle and only available with a copper or fiberglass kettle. It is an excellent sounding lightweight timpani that has found its way into the hands of timpani players all over the world.

### Kettle

The parabolic kettle is manufactured from copper or fiberglass-reinforced polyester (FRP). The FRP kettle is also available in a deep cambered version. Choose deep cambered for a warmer and darker sound or parabolic for a more light-footed character.

### Pedal and Feet

A unique balance spring renders the pedal action exceptionally light. The rear foot, the pedal and the front feet are entirely collapsible, which makes this timpani extraordinarily compact for transport – a set of 2 can be transported in the smallest car.

### Tuning gauge

All Majestic timpani are fitted with an extremely accurate, easily adjustable and eye-pleasing tuning gauge.

### Castors

The two front feet of a Majestic Harmonic timpani are equipped with braking castors which lock them in place during playing and make them easily transportable afterwards.

### Ranges and sizes

The Harmonic's have a range of almost 1 octave and come in the following sizes: 20", 23", 26", 29" and 32".

All Majestic timpani can be ordered in either American or German set up. Tuning gauges will be placed accordingly.

### Head and Frame

The heads used are Renaissance models manufactured by REMO. The frame is made entirely of cast aluminium so the timpani remains pleasantly light.



Also available with deep cambered kettles



Step 1



Step 2



Step 3



Step 4



Set of two in small car



Set of 2 with FRP kettles

## Concert Series

### The first transportable blocked pedal system timpani that is really easy to transport

Introduced in 2009, Majestic Concert Series timpani offer extremely light weight and advanced performance features. The blocked pedal system, in combination with the stable retractable four leg design, allows for an extended range of heights. Perfect for pit orchestra settings, younger players and even for drum set use. Now also available in customized colors to be even more attractive to younger players and for drum set use.

A double wheel set on the front makes the timpani stable when being transported. These timpani are uniquely designed to have a flat bottom when the legs are folded up, so they can be stored upright instead of on the head. And as a finishing touch they feature the newly designed, smoothest pedal system on the market. These innovations in combination with the deep cambered kettles will convince every timpani player.

#### Kettle

Deep cambered kettle is manufactured from fiberglass-reinforced polyester (FRP). These kettles produce a warm and dark sound. At special request the instruments can be equipped with deep cambered (hammered) copper kettles.

#### Pedal and Feet

A completely new design of the blocked pedal system renders the pedal action exceptionally light. The uniquely designed spring system ensures smooth pedal action over the full range of almost one octave. A total of four feet make these timpani very stable when being played. For transportation these feet slide into the kettle so the instruments can easily be stored upright instead of on the head because of the flat bottom. The two front legs are connected and have castors for easy transport on stage.

#### Tuning Gauge

Concert Series timpani are equipped with the well known and eye-pleasing Majestic tuning gauges, which are extremely accurate and easy adjustable.

#### Castors

The two connected front feet of Majestic Concert timpani are equipped with tall braking castors which lock them in place during playing and make them easy to transport afterwards.

#### Range and Sizes

The Concerts have a range of almost 1 octave each and come in the following sizes: 20", 23", 26", 29" and 32". Like all other Majestic timpani, they can be ordered in either American or German set up. Tuning gauges will be placed accordingly.

#### Heads

The heads used are standard white REMO® timpani heads. At an extra charge REMO Renaissance™ heads can be mounted. The frame is made of cast aluminum and laser cut steel so the timpani remains pleasantly light.





Unique blocked pedal





Accurate and easily adjustable tuning gauge

# Specification Chart

Timpani Series	Model No.	Size	Kettle	Pedal System	Remarks
Grand Classic Series 	GCBR20AH	20"	Cambered Copper Kettles Precision Hammered (fine)	Berlin (Ringer) w/ Ratched System	* Cast aluminum suspension frames with retractable wheels * Tuning gauge and hand fine tuners * Up to 1 1/4 octave range * Remo® Renaissance head
	GCBR23AH	23"			
	GCBR26AH	26"			
	GCBR29AH	29"			
	GCBR32AH	32"			
	GCBC20AH	20"	Cambered Copper Kettles Precision Hammered (fine)	Berlin (Ringer) w/ Clutch System	
	GCBC23AH	23"			
	GCBC26AH	26"			
	GCBC29AH	29"			
	GCBC32AH	32"			
	GCDC20AH	20"	Cambered Copper Kettles Precision Hammered (fine)	Dresden w/ Clutch System	
	GCDC23AH	23"			
GCDC26AH	26"				
GCDC29AH	29"				
GCDC32AH	32"				

Timpani Series	Model No.	Size	Kettle	Pedal System	Remarks
Symphonic Series 	MP2000AH	20"	Cambered Copper Hammered Kettles	Balance Style Pedal System	* Cast aluminum suspension frame with wheels * One piece copper bowl, including bearing edge * Up to 1 octave range * Remo® Renaissance head * All timpani include tuning key * 26" model includes mallet holder with mallets * All timpani include covers
	MP2300AH	23"			
	MP2600AH	26"			
	MP2900AH	29"			
	MP3200AH	32"			
	MP2000A	20"	Cambered Copper Kettles	Balance Style Pedal System	
	MP2300A	23"			
	MP2600A	26"			
	MP2900A	29"			
	MP3200A	32"			
	MPF2000A	20"	Cambered FRP Kettles	Balance Style Pedal System	
	MPF2300A	23"			
MPF2600A	26"				
MPF2900A	29"				
MPF3200A	32"				

\* Symphonic timpani are also available with Parabolic Copper and Parabolic FRP kettles

Timpani Series	Model No.	Size	Kettle	Pedal System	Remarks
Symphonic Grand Series 	GR2000AH	20"	Cambered Copper Hammered Kettles	Block Style Pedal System	* With hand and foot fine tuners * Up to 1 1/4 octave range * Remo® Renaissance head * All timpani include tuning key * 26" model includes mallet holder with mallets * 32" model includes mallets
	GR2300AH	23"			
	GR2600AH	26"			
	GR2900AH	29"			
	GR3200AH	32"			
	GRK2000A	20"	Cambered Copper Kettles	Block Style Pedal System	
	GRK2300A	23"			
	GRK2600A	26"			
	GRK2900A	29"			
	GRK3200A	32"			
Symphonic Grand Standard Series 	GRS2000AH	20"	Cambered Copper Hammered Kettles	Block Style Pedal System	* Without hand and foot fine tuner * Up to 1 octave range * Remo® Renaissance head * All timpani include tuning key * 26" model includes mallet holder with mallets * 32" model includes mallets
	GRS2300AH	23"			
	GRS2600AH	26"			
	GRS2900AH	29"			
	GRS3200AH	32"			
	GRSK2000A	20"	Cambered Copper Kettles	Block Style Pedal System	
	GRSK2300A	23"			
	GRSK2600A	26"			
	GRSK2900A	29"			
	GRSK3200A	32"			

\* Harmonic timpani are also available with Cambered FRP kettles and 20". Remo® standard white head is available.

Timpani Series	Model No.	Size	Kettle	Pedal System	Remarks
Harmonic Series 	MTK2300AP	23"	Parabolic Copper Kettles	Balance Style Pedal System	* Cast aluminum suspension frame with wheels * One piece copper bowl, including bearing edge * Up to 1 octave range * Remo® Renaissance head * All timpani include tuning key * 26" model includes mallet holder with mallets * All timpani include covers
	MTK2600AP	26"			
	MTK2900AP	29"			
	MTK3200AP	32"			
	MTG2300AP	23"			
	MTG2600AP	26"	Parabolic FRP Kettles	Balance Style Pedal System	
	MTG2900AP	29"			
	MTG3200AP	32"			

Timpani Series	Model No.	Size	Kettle	Pedal System	Remarks
Concert Series 	COC2000AH	20"	Cambered Copper Hammered Kettles	Block Style Pedal System	* Cast aluminum suspension frame with wheels * One piece copper bowl, including bearing edge * Up to 1 octave range * Remo® standard white heads * All timpani include tuning key * 26" model includes mallet holder with mallets
	COC2300AH	23"			
	COC2600AH	26"			
	COC2900AH	29"			
	COC3200AH	32"			
	COC2000A	20"	Cambered Copper Kettles	Block Style Pedal System	
	COC2300A	23"			
	COC2600A	26"			
	COC2900A	29"			
	COC3200A	32"			
	COF2000A	20"	Cambered FRP Kettles	Block Style Pedal System	
	COF2300A	23"			
	COF2600A	26"			
	COF2900A	29"			
COF3200A	32"				

\* Concert timpani are also available with Remo® Renaissance heads.

Timpani Series	Model No.	Size	Kettle	Pedal System	Remarks
Prophonic Series 	PR2000AH	20"	Cambered Copper Hammered Kettles	Balance Style Pedal System	* Up to 1 octave range * Remo® Renaissance head * All timpani include tuning key * 26" model includes mallet holder with mallets * 32" model includes mallets
	PR2300AH	23"			
	PR2600AH	26"			
	PR2900AH	29"			
	PR3200AH	32"			
	PR2000A	20"	Cambered Copper Kettles	Balance Style Pedal System	
	PR2300A	23"			
	PR2600A	26"			
	PR2900A	29"			
	PR3200A	32"			

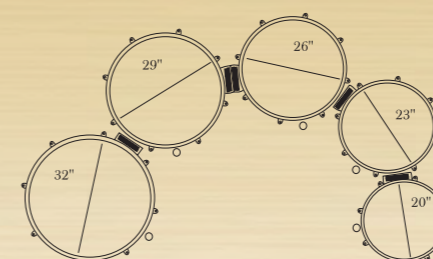

American Set-up

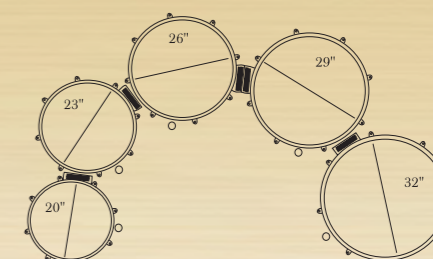

German Set-up

\* Model number ends with A/AH/AP refers to American Set-up; G/GH/GP for German Set-up.



Cover for Symphonic (Grand) / Cover Prophonic & Harmonic / Gig Bag Prophonic & Harmonic



Cover for Chimes & Concert Bass Drum - Stands for Concert Cymbals / Timpani mallets



Flightcase for Symphonic (Grand) / Timpani chairs from left to right: PSMA2302 - PS106 - PS232



MPK7 - MPK1 - MPK2 - MPK3 - MPK4 - MPK5 - MPK6 - MBK1 - #28 - #27 - BKL29 - Tuning keys

## Concert Bass Drums

### Prophonic Series

Majestic has a proud history of crafting quality concert bass drums utilizing full suspension hoops to maximize resonance and projection. Recently, time-tested quality features are being teamed with precision-made binary shells formed from select woods, such as maple and walnut. It has resulted in new series: the Prophonic Series.



**Shell:** 2 interior Walnut and 4 exterior Maple with Walnut layer and reinforcing rings  
**Finish:** Dark Coffee Lacquer  
**Suspension:** All around rubber suspension system in double rings for the best sustain  
**Frame:** Lockable 360° frame allows tilting at any angle  
**Hoops:** Internally chambered aluminum alloy hoops  
**Lugs:** Tube style lugs  
**Heads:** Remo® Fiberskyn 3  
**Sizes:** Available in 28"x18", 32"x18", 32"x22", 36"x18", 36"x22", 40"x18", 40"x22"  
**Stands:** Optional stand available for field (Quantum Series)  
**Accessories:** cover and mallet (except for bass drum only model)



Lockable 360°  
suspended frame (player side)

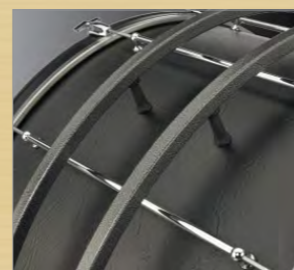

Fully suspended  
kettle mounting

\*Also available without stand

### Concert Series

The Concert Bass Drum series features a specially designed rubber mounting system, providing a suspended mounting sound in a standard frame design.



**Shell:** 7.2 mm Birch shell  
**Finish:** Black wood grain covering  
**Suspension:** Rubber suspension system in mounted frame  
**Frame:** Lockable 360° frame allows tilting at any angle  
**Hoops:** Black aluminum hoops  
**Lugs:** Tube style lugs  
**Heads:** Remo® Fiberskyn 3  
**Sizes:** Available in 28"x14", 28"x16", 28"x18", 32"x18", 32"x22", 36"x18", 36"x22", 40"x18", 40"x22"  
**Stands:** Optional stand available for field (Quantum Series)  
**Accessories:** cover and mallet (except for bass drum only model)



Front 360° suspended frame



Remo Fiberskyn in 3 heads



\*Also available without stand



"I really love the fat, enveloping tone produced by the thin maple and walnut shells of the Majestic Prophonic series toms and bass drum. These shells and the I.T.S. mounting system create a sound which can be felt. I also like very much that this hardware allows easy positioning within my multi-percussion set-ups."

#### Nebojsa Jovan Zivkovic

Majestic Concert Percussion Artist,  
World Renowned Percussion Composer and Performer



## Concert Toms

Majestic's newly designed Concert Toms are available in two different series: the Prophonic Series and the Concert Series. The Prophonic Series has thin maple shells with a lacquered walnut interior. Combined with the patented Isolated Tom Mount System (ITS) and single pointed mounted lugs, it provides a warm, opened and focused sound. The Concert Series has thicker maple/birch shells with black wood grain covering. Also mounted with ITS, it provides great sound.

### Prophonic Series **NEW**

- Single headed toms (double headed also available at an extra charge)
- 5.1 mm shell featuring four outer plys of maple with two interior plys of walnut
- Dark Coffee lacquer finish
- Remo® Renaissance™ heads
- 2.3 mm chrome plated steel hoops
- Patented I.T.S. suspension mounted system
- Single point mounted lugs, with off-the-shell design
- Sizes: available in 6"x8", 8"x8", 10"x9", 12"x10", 13"x11", 14"x12", 15"x13", 16"x14"



### Concert Series

- Single headed toms (double headed also available at an extra charge)
- 7.2 mm maple/birch shell
- Black wood grain covering
- Remo® UT™ Clear heads
- 1.6 mm chrome plated steel hoops
- Patented I.T.S. suspension mounted system
- Single screw low mass lugs
- Sizes: available in 6"x8", 8"x8", 10"x10", 12"x10", 13"x11", 14"x12", 15"x14", 16"x14"



# Concert Snare Drums

Choose a snare drum depending on your personal preference

Majestic concert snare drums are available with a variety of materials and sound qualities. Depending on your personal preferences you can choose from Aluminum, Brass, Walnut or Maple shells in 3.5", 5", 5.5" and 6.5" high.

## Prophonic Series **NEW**

Majestic's new Prophonic concert snare drums bring innovative technology to the art of snare drum musicianship. It's newly designed mechanism allows for the use of up to four different types of snare material simultaneously, each with individual tension adjustment and throw off levers, while still allowing all to be engaged or disengaged together with a master switch. This unique feature combined with a variety of available shell configurations and many options for snare type allow the Prophonic snare drum to be easily configured for a multitude of concert settings. From the largest orchestra hall to the most intimate chamber setting, the Prophonic sets the new standard for the professional classical percussionist.



MPS 1455AL

MPS 1455WA

### 8 snare options

No.	Model number	Description	Material	Number of strings
1	RK2	Red beads	Glass Ø2 / Guitar strings	2
2	SNM6	Snare wires	Spiral steel wires	6
3	MS8	Black cord	Woven nylon cord	8
4	STS8	Steel cable	Stainless steel 1mm	8
5	TSN6	Gut snare	Black nylon	6
6	MC8	Bleu cable	Coated steel	8
7	GS8	Guitar strings	Phosphor Bronze Ø0,89	8
8	HK1	Wood beads	Wood Ø4 / Guitar strings	1

\* Standard Prophonic snare drum includes No.1~4 cables; all cables are available separately.



Master switch to engage / disengage simultaneously



Individual throw off levers for separate tension adjustment

## Concert Series

Majestic's Concert Series Snare Drums are available with a variety of materials and sound qualities.

All models have the following in common:

- \* Solid die-cast tension hoops
- \* Ten tension lugs for optimal head tension
- \* Majestic's 25-strand steel wire snares
- \* Single-handle smooth operation snare system
- \* Snare tension adjustment on left and right sides
- \* Remo Renaissance heads on batter and snare sides

Depending on your personal preferences you can choose from the following kettle qualities.



MCS 1465AL

MCS 1455AL

Aluminium kettle (3 mm)  
MCS1465AL (14"x6.5") and MCS1455AL (14"x5.5").  
MCS1335AL (13"x3.5") is now available.



MCS 1465MA

MCS 1455MA

Maple kettle (7.2 mm)  
MCS1465MA (14"x6.5") and MCS1455MA (14"x5.5").



MCS 1465BR

MCS 1455BR

Brass kettle (1.2 mm)  
MCS1465BR (14"x6.5") and MCS1455BR (14"x5.5").  
MCS1335BR (13"x3.5") is now available.



## Concert Bass Drums Specification Chart



Series	Model No.	Size	Kettle	Stand	Remarks
Prophonic Series	MPB2818	28" X 18"	Walnut/Maple	Suspension Stand	* Remo® Fiberskyn 3. * All concert bass drums include covers & mallet (except for bass drum only model) * Model number start with "PBD" represents Bass drum without stand.
	MPB3218	32" X 18"			
	MPB3222	32" X 22"			
	MPB3618	36" X 18"			
	MPB3622	36" X 22"			
	MPB4018	40" X 18"			
	MPB4022	40" X 22"			
	MFPB2818	28" X 18"	Walnut/Maple	Field Suspension Stand	
	MFPB3218	32" X 18"			
	MFPB3222	32" X 22"			
	MFPB3618	36" X 18"			
	MFPB3622	36" X 22"			
	MFPB4018	40" X 18"			
	MFPB4022	40" X 22"			



## Concert Toms Specification Chart



Series	Model No.	Size	Kettle	Head	Hoop
Prophonic Series	MCTP0608D	6" X 8"	Walnut/Maple	Double Headed Remo® Renaissance™	2.3mm Steel Hoop
	MCTP0808D	8" X 8"			
	MCTP1009D	10" X 9"			
	MCTP1210D	12" X 10"			
	MCTP1311D	13" X 11"			
	MCTP1412D	14" X 12"			
	MCTP1513D	16" X 14"			
	MCTP1614D	40" X 22"			
	MCTP0608S	6" X 8"	Walnut/Maple	Single Headed Remo® Renaissance™	2.3mm Steel Hoop
	MCTP0808S	8" X 8"			
	MCTP1009S	10" X 10"			
	MCTP1210S	12" X 10"			
	MCTP1311S	13" X 11"			
	MCTP1412S	14" X 12"			
	MCTP1513S	15" X 13"			
	MCTP1614S	16" X 14"			

Series	Model No.	Size	Kettle	Stand	Remarks
Concert Series	MCB2814	28" X 14"	All Birch	Tilting Stand	* Remo® Fiberskyn 3. * All concert bass drums include covers & mallet. (except for bass drum only model) * Model number start with "CBD" represents Bass drum without stand.
	MCB2816	28" X 16"			
	MCB2818	28" X 18"			
	MCB3218	32" X 18"			
	MCB3222	32" X 22"			
	MCB3618	36" X 18"			
	MCB3622	36" X 22"			
	MCB4018	40" X 18"			
	MCB4022	40" X 22"			
	MFCB2814	28" X 14"			
	MFCB2816	28" X 16"			
	MFCB2818	28" X 18"			
	MFCB3218	32" X 18"			
	MFCB3222	32" X 22"			
	MFCB3618	36" X 18"			
	MFCB3622	36" X 22"			
	MFCB4018	40" X 18"			
	MFCB4022	40" X 22"			

Series	Model No.	Size	Kettle	Head	Hoop
Concert Series	MCTC0608D	6" X 8"	Birch/Maple	Double Headed Remo® Renaissance™	1.6mm Steel Hoop
	MCTC0808D	8" X 8"			
	MCTC1010D	10" X 10"			
	MCTC1210D	12" X 10"			
	MCTC1311D	13" X 11"			
	MCTC1412D	14" X 12"			
	MCTC1514D	15" X 14"			
	MCTC1614D	16" X 14"			
	MCTC0608S	6" X 8"	Birch/Maple	Single Headed Remo® Renaissance™	1.6mm Steel Hoop
	MCTC0808S	8" X 8"			
	MCTC1010S	10" X 10"			
	MCTC1210S	12" X 10"			
	MCTC1311S	13" X 11"			
	MCTC1412S	14" X 12"			
	MCTC1514S	15" X 14"			
	MCTC1614S	16" X 14"			



## Concert Snare Drums Specification Chart



Series	Model No.	Size	Kettle	Head	Hoops
Prophonic Series	MPS1455WA	14" X 5.5"	Walnut 5.1mm	Remo® Renaissance™	Zinc Alloy
	MPS1465WA	14" X 6.5"			
	MPS1455AL	14" X 5.5"	Aluminum 3mm		
	MPS1465AL	14" X 6.5"			
Concert Series	MCS1335BR	14" X 3.5"	Brass 1.2mm	Remo® Renaissance™	Zinc Alloy
	MCS1455BR	14" X 5.5"			
	MCS1465BR	14" X 6.5"			
	MCS1335AL	14" X 3.5"	Aluminum 3mm		
	MCS1455AL	14" X 5.5"			
	MCS1465AL	14" X 6.5"			
	MCS1455MA	14" X 5.5"			
MCS1465MA	14" X 6.5"				



### Professional Series : M8650H

Octave : 5	Length : 294 cm
Range : C2 - C7	Width (Low end) : 112 cm
Bar : Wide Honduran Rosewood	Width (High end) : 70 cm
Bar Sizes : 41 ~ 82 mm	Height : 90 ~ 107 cm
Pitch : A=442 Hz	



Rounded bar edge

## Marimba

All Majestic marimbas utilize advanced tuning methods developed in consultation with master tuners in the U.S. and Europe. By pairing these methods with carefully selected aged Honduran rosewood or the warm resonance of newly formulated synthetic bar material, consistently balanced keyboards are produced. With these keyboards over precision-tuned resonators, the resulting tone production is full, balanced and consistent. Add to this effortless height adjustment and easy rolling casters, and it is clear that Majestic marimbas represent the convergence of design elegance, superior tone, and ultimate functionality.

The Professional series five octave marimba is set apart by its beautiful wood frame and classic curves. From the offset arch of the front resonator to the graceful curves of the ultra-stable legs, this instrument exudes beauty and class.

Professional series marimbas are made from selected wood that is manufactured with the highest degree of technology and craftsmanship. The wood rails and end pieces are strong yet streamlined, giving the instrument a solid, classical appearance.

A Majestic marimba resonator is individually made with thicker material, increasing the strength of the entire set. For 5 and 4 1/3 octave marimbas, adjustable resonator stabilizers enable the player to fine-tune adjustments to compensate for changes in humidity and to ensure tonal quality and optimal resonance and acoustic fidelity. The time-honored curved shape is representative of the luxurious style of the golden age, and the offset arch resonators are specially designed using computerized technology.

The height adjustment feature on the legs provides effortless adjustments and increases balance and stability, which in turn leads to enhanced durability and functionality. For 5 octave marimbas, the stand is specifically built for this heavy instrument and has a strong structural design to ensure solidness. For 4 1/3, 4 & 3 octave marimbas, the light weight design permits easy movement, fast and quick assembly and multi-functional usage for both professionals and schools.

The Professional series marimbas are available in 5 octaves, Artist series marimbas are available in 4 1/3 octaves, and Deluxe series marimbas are available in 5 and 4 1/3, 4 and 3 octaves.

"The tuning on Majestic M8650H is great, and it is an absolute joy to play. The low register resonance is very stable at all dynamic levels, with a nice and neutral sound."

#### Pedro Carneiro

Majestic Marimba Artist,  
One of the World's Foremost Solo Classical Percussionists





**Artist Series : M7750H**

**NEW**

• M7750H

Octave : 5  
 Range : C2 - C7  
 Bar : Honduras Rosewood  
 Bar Sizes : 41 ~ 82 mm  
 Pitch : A = 442 Hz

Length : 294 cm  
 Width (low end) : 112 cm  
 (high end) : 70 cm  
 Height : 90~107 cm



• M6543H

• M6543D

**Deluxe Series : M6543H, M6543D, M6543P**

Octave : 4 1/3  
 Range : A2 - C7  
 Bar : Honduras Rosewood (M6543H)  
       Padauk (M6543D)  
       Synthetic (M6543P)  
 Bar Sizes : 38 ~ 63 mm  
 Pitch : A = 442 Hz

Length : 227 cm  
 Width (low end) : 90 cm  
 (high end) : 65 cm  
 Height : 90 ~ 115 cm

**Artist Series : M7743H**

**NEW**

• M7743H

Octave : 4 1/3  
 Range : A2 - C7  
 Bar : Honduras Rosewood  
 Bar Sizes : 41 ~ 76 mm  
 Pitch : A = 442 Hz

Length : 222 cm  
 Width (low end) : 100 cm  
 (high end) : 65 cm  
 Height : 90 ~ 115 cm



**Deluxe Series : M6540P**

Octave : 4  
 Range : C3 - C7  
 Bar : Synthetic  
 Bar Sizes : 38 ~ 50 mm  
 Pitch : A=442 Hz

Length : 224 cm  
 Width (Low end) : 78 cm  
 Width (High end) : 65 cm  
 Height : 90 ~ 115 cm



• M6540P

**Artist Series : M7550P**

Octave : 5  
 Range : C2 - C7  
 Bar : Synthetic  
 Bar Sizes : 38 ~76 mm  
 Pitch : A = 442 Hz

Length : 273 cm  
 Width (low end) : 89 cm  
 (high end) : 65 cm  
 Height : 90~107 cm



• M7550P

**Deluxe Series : M6530P**

Octave : 3  
 Range : F3 - F6  
 Bar : Synthetic  
 Bar Sizes : 38 mm  
 Pitch : A-442 Hz

Length : 142 cm  
 Width (Low end) : 70 cm  
 Width (High end) : 65 cm  
 Height : 90 ~ 115 cm



• M6530P

# Xylophone

Majestic xylophones incorporate a unique feature for easy height adjustments with strictly selected Honduran Rosewood bars, making it an excellent choice for any player. Majestic xylophones are available in 3 1/2 octaves and 4 octaves, an exceptional choice for players who want to perform a wider range of musical selections.



## Professional Series : X8540H

Octave : 4  
 Range : C4 - C8  
 Bar : Honduras Rosewood  
 Bar Sizes : 38 ~ 41mm  
 Pitch : A=442 Hz

Length : 174 cm  
 Width (Low end) : 89 cm  
 Width (High end) : 65 cm  
 Height : 90 ~ 115 cm

• X8540H



## Artist Series : X7535H

Octave : 3 1/2  
 Range : F4 - C8  
 Bar : Honduras Rosewood  
 Bar Sizes : 38 mm  
 Pitch : A=442 Hz

Length : 160 cm  
 Width (Low end) : 82 cm  
 Width (High end) : 65 cm  
 Height : 90 ~ 115 cm

• X7535H

Crafted from the finest quality aged Honduran Rosewood or newly formulated synthetic bar material, Majestic xylophones provide extraordinary options for all types of performance. With discriminating attention to tuning and materials, the tone is bright and musical. The frames are lightweight and portable, easy to roll and have incredibly easy height adjustment.

## Deluxe Series : X6540P

Octave : 4  
 Range : C4 - C8  
 Bar : Synthetic  
 Bar Sizes : 38 mm  
 Pitch : A=442 Hz

Length : 170 cm  
 Width (Low end) : 70 cm  
 Width (High end) : 65 cm  
 Height : 90 ~ 115 cm



• X6540P

## Deluxe Series: X6535H, X6535D, X6535P

Octave : 3 1/2  
 Range : F4 - C8  
 Bar : Honduras Rosewood (X6535H)  
       Padauk (X6535D)  
       Synthetic (X6535P)  
 Bar Sizes : 38 mm  
 Pitch : A = 442 Hz

Length : 157 cm  
 Width (low end) : 70 cm  
 (high end) : 65 cm  
 Height : 90 ~ 115 cm



• X6535H

• X6535D

## Vibraphone

The Majestic Artist vibraphones are available in the most popular 3 octave range and offer a very warm, full-bodied tone that is perfectly balanced throughout the range of the instrument. The wide pedal design with twin pull rods allows the performer to play freely and also creates a more efficient damping mechanism. The Majestic Artist vibraphones offer both bars and resonators in gold or silver finish.



### Artist Series : V7530G / V7530S

Octave : 3	Length : 164 cm
Range : F3 - F6	Width (Low end) : 78 cm
Bar : Aluminum	Width (High end) : 65 cm
Bar Sizes : 38 ~ 57 mm	Height : 90 ~ 115 cm
Pitch : A=442 Hz	



### Deluxe Series : V6530S

Octave : 3	Length : 164 cm
Range : F3 - F6	Width (Low end) : 71cm
Bar : Aluminum	Width (High end) : 65 cm
Bar Sizes : 38 ~ 44 mm	Height : 90 ~ 115 cm
Pitch : A=442 Hz	

\* Vibraphone without motor is also available (V6530SX)

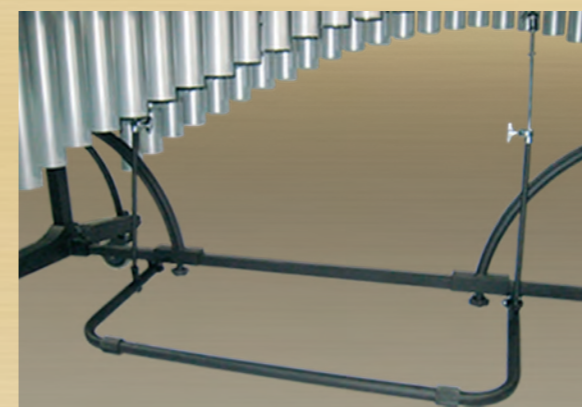

**Pedal**  
The wide pedal design with twin pull rods offers player comfort and reliability.



**Cogged belt**  
The Cogged belt increases stability and during damping, allows the pulsator shaft to stop at the same position. The reinforced cogged belt ensures precise alignment of the rotors of both resonator banks and provides reliable performance over time.

## Bells

Majestic Orchestra bells feature an innovative single pin mounted bar that produces a brighter and clearer tone, making them the leading choice among musicians. Majestic bells are available in 2.5 octaves with either aluminum or high carbon steel bars. Orchestra model bells have a deeper wood case that produces tremendous resonance and sustain.



• B3525A

• B3525S

### Orchestra Bells : B3525S

Octave : 2 1/2      Length : 82 cm  
 Range : G5 - C8      Width (Low end) : 51 cm  
 Bar : Steel      Width (High end) : 28 cm  
 Bar Sizes : 32 mm      Height : 13 cm  
 Pitch : A=442 Hz

### Concert Bells : B3525A

Octave : 2 1/2      Length : 76 cm  
 Range : G5 - C8      Width (Low end) : 47 cm  
 Bar : Alumium      Width (High end) : 24 cm  
 Bar Sizes : 32 mm      Height : 9 cm  
 Pitch : A=442 Hz



• AZ02 Folding Bell Stand



• AZ03 Rolling Cart for Orchestra Bells

## Marching Bells

Featuring the same precision tuned bars and keyboards of their concert counterparts, Majestic marching bells provide maximum projection on the field. The rugged marching frame and harness system is easily adjustable and ensures stability while marching. Instruments come complete with carrying bags for the keyboard and harness.

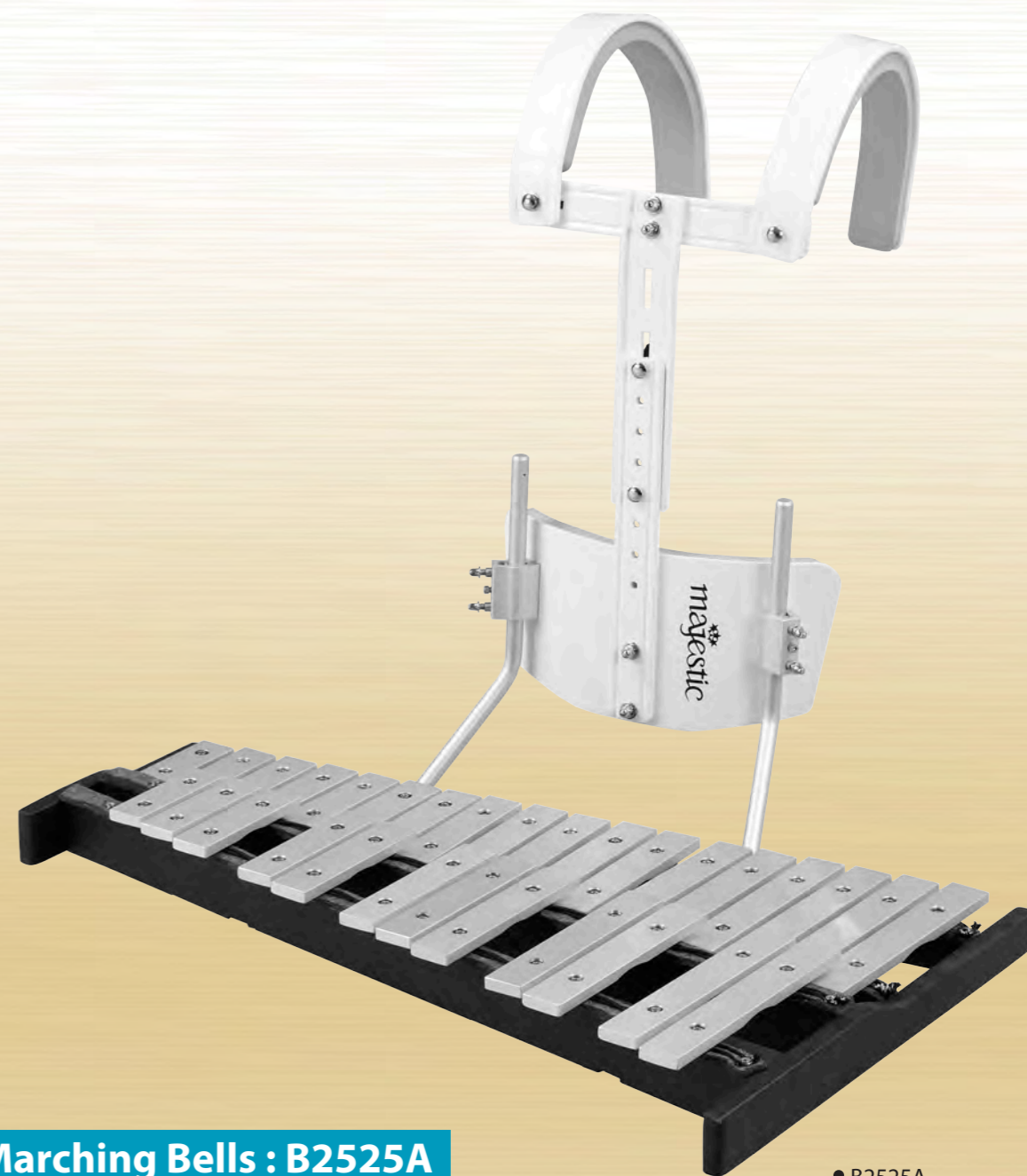

• B2525A

### Marching Bells : B2525A

Octave : 2 1/2      Length : 74 cm  
 Range : G5 - C8      Low end : 45 cm  
 Bar : Aluminum      High end : 22 cm  
 Bar Sizes : 32 mm  
 Pitch : A=442 Hz

## Chimes

For players of all levels Majestic offers the largest choice of chimes in the Professional, Artist and Deluxe series. Featuring 18, 20, and 22 note models in your choice of 1 1/2" and 1 1/4" tubes with either lacquered brass tubes or chrome-plated brass tubes. Majestic has the perfect chimes for any application.

### Professional Series : C8622C / C8622B

Range : A4# - G6  
 Tube : 22 notes  
 1 1/2" diameter  
 Chrome-plated (B8266C)  
 Lacquered (B8266B)  
 Pitch : A=442 Hz

Length : 106 cm  
 Width : 62 cm  
 Height : 182 cm



• C8622B

• C8622C

### Artist Series : C7620C / C7620B

Range : C5 - G6  
 Tube : 20 notes  
 1 1/2" diameter  
 Chrome-plated (C7620C)  
 Lacquered (C7620B)  
 Pitch : A=442 Hz

Length : 100 cm  
 Width : 62 cm  
 Height : 179 cm



• C7620B

• C7620C

Majestic chimes deliver profound resonance and an unparalleled constancy of tone. The enclosed damper box protects the mechanism and ensures unhindered smooth pedal operation.

### Deluxe Series : C6618C / C6618B

Range : C5 - F6  
 Tube : 18 notes  
 1 1/2" diameter  
 Chrome-plated (C6618C)  
 Lacquered (C6618B)  
 Pitch : A=442 Hz

Length : 92 cm  
 Width : 62 cm  
 Height : 178 cm



• C6618B



• C6618C

• C6618B

### Deluxe Series : C6518C / C6518B

Range : C5 - F6  
 Tube : 18 notes  
 1 1/4" diameter  
 Chrome plated (C6518C)  
 Lacquered (C6518B)  
 Pitch : A=442 Hz

Length : 92 cm  
 Width : 62 cm  
 Height : 178 cm

### Dinner Chimes : R40, R50

Range : G - C - E - G  
 Bar : Aluminum, Gold  
 Resonator : Tuned, Gold (R40)  
 Tuned, Black (R50)



• R50

• R40



# Majestic Field Mallet Instruments

## Quantum Series

The new Majestic Quantum field frame is the ultimate in rugged performance and offers modular and flexible mounting options. With many available mounting points and optional horizontal and vertical rack bars included, the Quantum frame puts auxiliary keyboards, drums, percussion items, microphones, and powered speakers right where you need them. The pneumatic cylinder assisted height adjustment allows for easy and reliable ergonomic positioning of the keyboard. A two position speaker post and an additional center microphone mounting bar allow for easy interface with amplification equipment.



• M1550P with optional accessories



AQ01 Cymbal Boom Arm



AQ02 Snare Basket Arm



AQ03 Microphone Boom Arm



AQ06 Open Front Trap Tray w/ Mount Arm



AQ07 Marching Bell Arms

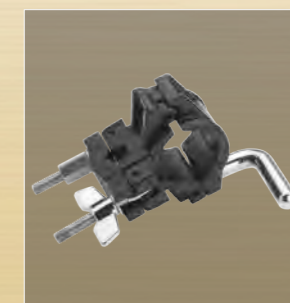

AQ08 Crossbar Accessory Mounting Clamp



AQ09 Memory Lock



AQ11 T-Clamp

## Quantum Marimba

Majestic Quantum series marimbas feature a newly formulated synthetic bar material for the best possible performance in all environments. These bars have unprecedented warmth of tone for a synthetic material and a wood like appearance. Precision tuning methods ensure the highest level of tonal consistency.



### Quantum Series : M1550P

Octave : 5	Length : 284 cm
Range : C2 - C7	Width (Low end) : 101 cm
Bar : Synthetic	Width (High end) : 77 cm
Bar Sizes : 38 ~ 76 mm	Height : 90 ~ 110 cm
Pitch : A=442 Hz	

• M1550P



### Quantum Series : M1543P

Octave : 4 1/3	Length : 237 cm
Range : A2 - C7	Width (Low end) : 97 cm
Bar : Synthetic	Width (High end) : 77 cm
Bar Sizes : 38 ~ 63 mm	Height : 90 ~ 110 cm
Pitch : A=442 Hz	

• M1543P

## Quantum Xylophone

Majestic Quantum series xylophones also utilize our newly formulated synthetic bar material with a warm tone and a wood like appearance. Traditional American style tuning methods are employed with the utmost in accuracy to ensure a bright and musical characteristic tone.

### Quantum Series : X1535P

Octave : 3 1/2	Length : 167 cm
Range : F4 - C8	Width (Low end) : 77 cm
Bar : Synthetic	Width (High end) : 77 cm
Bar Sizes : 38 mm	Height : 90 ~ 110 cm
Pitch : A=442 Hz	



• X1535P

## Quantum Vibraphone

With the Majestic Quantum vibraphone, you don't have to sacrifice warmth for projection. The big, full-bodied tone produced by these instruments can fill stadiums without becoming bright or thin sounding. The wide pedal design with twin pull rods offers players comfort and reliability.



• V1530G

• V1530S

### Quantum Series : V1530G / V1530S

Octave : 3	Length : 174 cm	Width
Range : F3 - F6	Width (Low end) : 77 cm	
Bar : Aluminum	Width (High end) : 77 cm	
Bar Sizes : 38 ~ 57 mm	Height : 90 ~ 110 cm	
Pitch : A=442 Hz		

\*Quantum Vibraphone without motor is also available (V1530SX)

# Quantum Chimes

Large, 8" pneumatic tires and a wide wheel base make the Majestic Quantum Chimes a stable and smooth-rolling choice indoors and out. The enclosed damper box protects the mechanism and ensures unhindered smooth pedal operation.

## Specification Chart

### Quantum Series : C1618C / C1618B

Range : C5 - G6                      Length : 92 cm  
 Tube : 18 notes                      Width : 75 cm  
          1 1/2" diameter                      Height : 186 cm  
          Chrome-plated (C1618C)  
          Lacquered (C1618B)  
 Pitch : A=442 Hz

### Quantum Series : C1518C / C1518B

Range : C5 - F6                      Length : 92 cm  
 Tube : 18 notes                      Width : 75 cm  
          1 1/4" diameter                      Height : 178 cm  
          Chrome-plated (C1518C)  
          Lacquered (C1518B)  
 Pitch : A=442 Hz



• C1618C

• C1518B

# Quantum Bass Drum



• MFCB3622



• SFB40 field suspension stand

• MPB4022 with concert frame

See page 27~28 and 33 for features and specifications

		Series	Model No.	Octave	Range	Notes	Bars / Tubes	Graduation	Remark
Concert Mallets	Marimba	Professional	M8650H	5	C2-C7	61	Honduras Rosewood	7	Wide Bars
		Artist	M7750H	5	C2-C7	61	Honduras Rosewood	5	Wide Bars
		Artist	M7550P	5	C2-C7	61	Synthetic	5	
		Artist	M7743H	4 1/3	A2-C7	52	Honduras Rosewood	5	Wide Bars
		Deluxe	M6543H	4 1/3	A2-C7	52	Honduras Rosewood	5	
		Deluxe	M6543D	4 1/3	A2-C7	52	Padauk	5	
		Deluxe	M6543P	4 1/3	A2-C7	52	Synthetic	5	
		Deluxe	M6540P	4	C3-C7	49	Synthetic	3	
	Deluxe	M6530P	3	F3-F6	37	Synthetic	1		
	Xylophone	Professional	X8540H	4	C4-C8	49	Honduras Rosewood	2	
		Artist	X7535H	3 1/2	F4-C8	44	Honduras Rosewood	1	
		Deluxe	X6540P	4	C4-C8	49	Synthetic	1	
		Deluxe	X6535H	3 1/2	F4-C8	44	Honduras Rosewood	1	
		Deluxe	X6535D	3 1/2	F4-C8	44	Padauk	1	
		Deluxe	X6535P	3 1/2	F4-C8	44	Synthetic	1	
	Vibraphone	Artist	V7530G	3	F3-F6	37	Aluminum Gold	4	
		Artist	V7530S	3	F3-F6	37	Aluminum Silver	4	
		Deluxe	V6530S	3	F3-F6	37	Aluminum Silver	2	
		Deluxe	V6530SX	3	F3-F6	37	Aluminum Silver	2	w/o Motor
	Chimes	Professional	C8622C	1 3/4	A4#-G6	22	1 1/2" Chrome-plated Brass Tubes	1	
		Professional	C8622B	1 3/4	A4#-G6	22	1 1/2" Lacquered Brass Tubes	1	
		Artist	C7620C	1 1/2	C5-G6	20	1 1/2" Chrome-plated Brass Tubes	1	
		Artist	C7620B	1 1/2	C5-G6	20	1 1/2" Lacquered Brass Tubes	1	
		Deluxe	C6618C	1 1/2	C5-F6	18	1 1/2" Chrome-plated Brass Tubes	1	
Deluxe		C6618B	1 1/2	C5-F6	18	1 1/2" Lacquered Brass Tubes	1		
Deluxe	C6518C	1 1/2	C5-F6	18	1 1/4" Chrome-plated Brass Tubes	1			
Deluxe	C6518B	1 1/2	C5-F6	18	1 1/4" Lacquered Brass Tubes	1			

\* Mallets and Dust cover included.

			Model No.	Octave	Range	Notes	Bars	Graduation	Remark
Bells	Orchestra	B3525S	B3525S	2 1/2	G5-C8	30	Steel	1	w/ Hard Case
	Concert	B3525A	B3525A	2 1/2	G5-C8	30	Aluminum Silver	1	w/ Hard Case
	Marching	B2525A	B2525A	2 1/2	G5-C8	30	Aluminum Silver	1	w/ Carrier

\* Mallets included.

		Series	Model No.	Octave	Range	Notes	Bars / Tubes	Graduation	Remark	
Field Mallets	Marimba	Quantum	M1550P	5	C2-C7	61	Synthetic	7		
		Quantum	M1543P	4 1/3	A2-C7	52	Synthetic	5		
	Xylophone	Quantum	X1535P	3 1/2	F4-C8	44	Synthetic	1		
		Quantum	V1530G	3	F3-F6	37	Aluminum Gold	4		
	Vibraphone	Quantum	V1530S	3	F3-F6	37	Aluminum Silver	4		
		Quantum	V1530SX	3	F3-F6	37	Aluminum Silver	4	w/o Motor	
	Chimes	Quantum	C1618C	C1618C	1 1/2	C5-F6	18	1 1/2" Chrome-plated Brass Tubes	1	
		Quantum	C1618B	C1618B	1 1/2	C5-F6	18	1 1/2" Lacquered Brass Tubes	1	
		Quantum	C1518C	C1518C	1 1/2	C5-F6	18	1 1/4" Chrome-plated Brass Tubes	1	
		Quantum	C1518B	C1518B	1 1/2	C5-F6	18	1 1/4" Lacquered Brass Tubes	1	

\* Mallets and Dust cover included.

### Mallets Scale Map

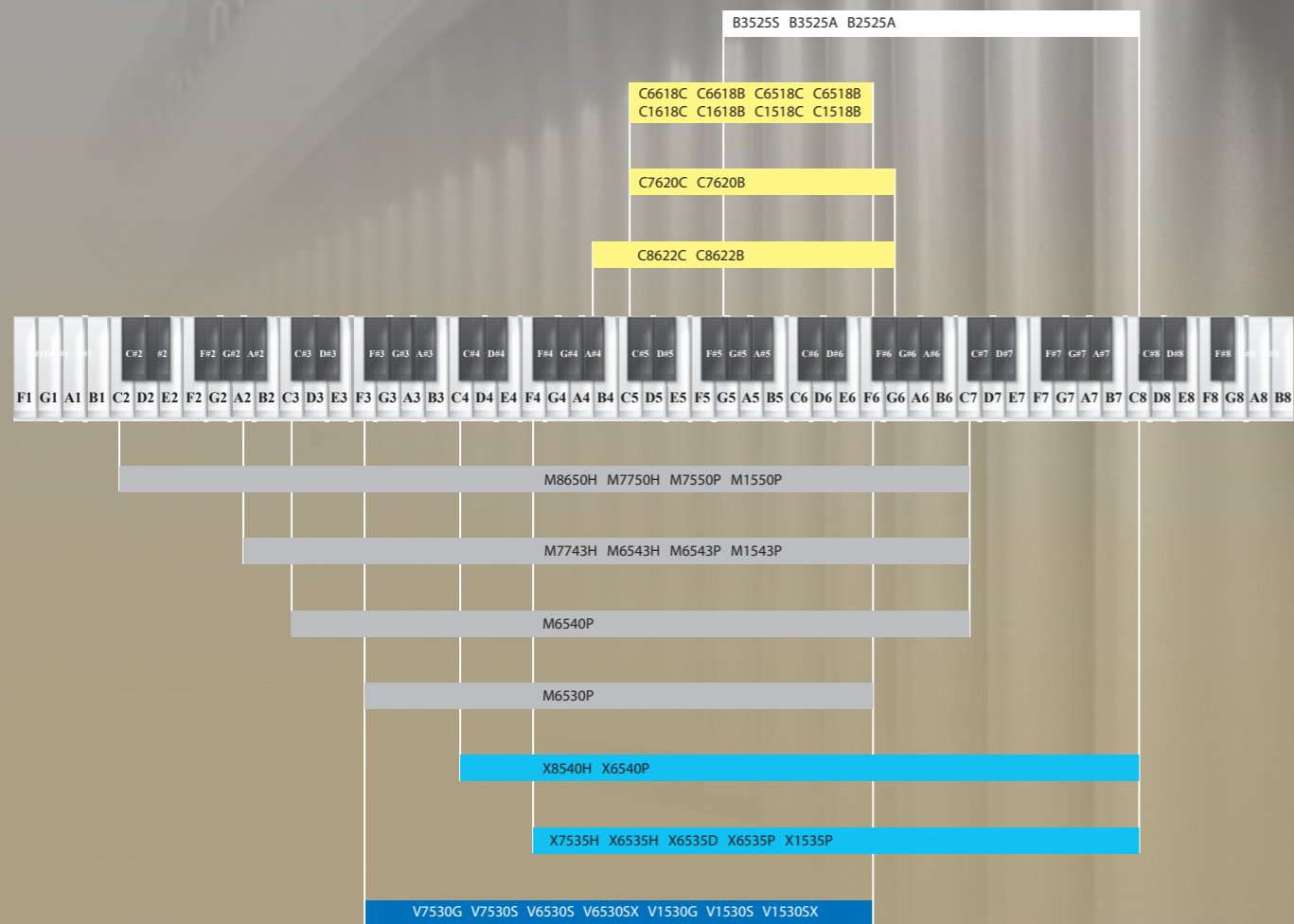

### Percussion Kits

Majestic percussion instruments are designed to give players their best chance of success. Percussion Kits are rugged and durable, and featuring high quality keyboards, snare drums, and practice pad. Protective rolling cases ensure the kits are transported safely and comfortably.



• AK32PB



• AK14D



• AK1432DP



• AK32PC

Model No.	Bell Keyboard	Drum Pad	Snare Drum	Case
AK1432DP	2 1/2 Octaves (F5-C8)	8" Tunable	14"x3.5", 10 Lug Chrome	Cart w/ Wheels & Handle
AK32P			—	Backpack
AK32PC		—	—	Cart w/ Wheels & Handle
AK32PB		—	—	Backpack
AK14D	—	Gladstone type	14"x5", 10 Lug Chrome	Backpack
AK14DC	—		—	Cart w/ Wheels & Handle